

FSW Series

FSW 1134

FLAME PROOF ISOLATOR (10 A)



Mechanical Data

Material	: Aluminium LM6
Weight	: 0.8 Kg (Approx.)
IP Protection	: IP 65 to IS 13947
Finish	: Anti corrosive Epoxy powder coated
Cable Entry	: 2 x (3/4" ET / 0.5" NPT / BSP / M20)
Gasket	: Neoprene
Hardware	: Stainless Steel (SS-304)

Electrical Data

Voltage	V : 230 V AC, 50 Hz
Max. Current	A : 10 Amps
No. Of Poles	: Double Pole
Max. Cable Size	: 3C x 4 sq.mm
Earthing	: External : 2 Nos - M6 Internal : 1 No - M5



Description

Explosion proof, weather proof toggle switch with facilities to mount up to 10 A DP switch. A special design of operating parts ensure firm and reliable toggle action. The switch is made weather proof with neoprene gaskets and can therefore provide reliable switching action both indoors and outdoors.

GA drawing

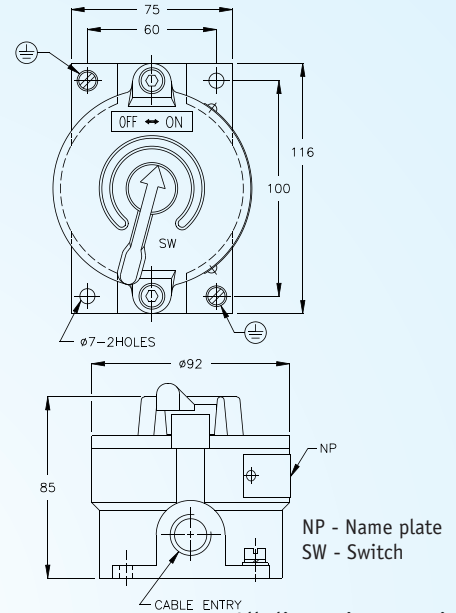

All dimensions are in mm

Type of protection	Flame Proof - Exd
Area Classification	Zone 1 & 2
Gas Groups	Group I, II A, II B
Apparatus Standard	IS - 2148 / 81
CMRI Certificate No.	CMRS / TC / H 524
Approvals	CCE

Variations

FSW 1131	- Single pole
FSW 1132	- Double pole

CMRI CERTIFIED

CERTIFICATES
CMRI | CCE | BIS

www.baliga.com



SWITCHES