

FPBS Series

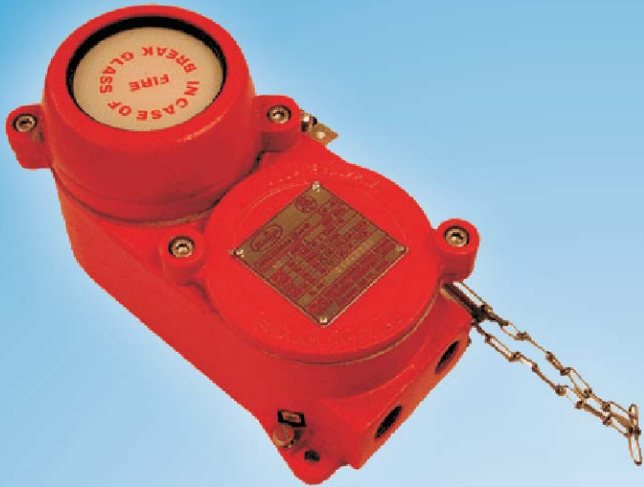

FPBS 52100 FA

FLAME PROOF FIRE ALARM STATION



Mechanical Data

- Material : Aluminium LM6
- Weight : 3.0 Kg (Approx.,)
- IP Protection : IP 65
- Finish : Anti corrosive epoxy powder coated
- Cable Entry : 2 x 3/4" ET
- Gasket : Neoprene
- Hardware : Stainless Steel (SS-304)

Electrical Data

- Contact Element : INC
- Rating Voltage : 500 V, 50 Hz AC
- Terminals : 4 x 2.5 sq.mm
- Earthing : External : 2 Nos - M6
Internal : 1 No - M5

Description

Explosion proof Fire Alarm control station with an integral terminal chamber. A push button actuator with a mushroom head is provided in the main chamber. This actuator is in constant contact with a glass cover which when broken activates the alarm. A single contact element in the main chamber is wired to terminals in the terminal chamber through sealed explosion proof bushings. The alarm station is provided with gaskets for weather proof protection.

GA Drawing

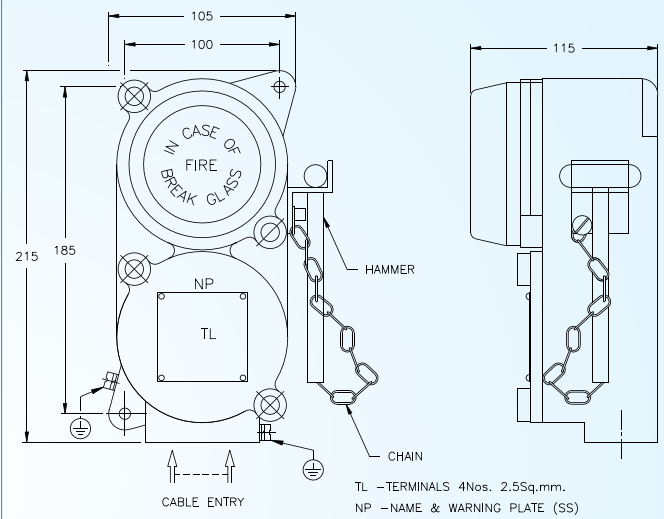

All dimensions are in mm

Type of protection	Flame Proof - Exd
Area Classification	Zone 1 & 2
Gas Groups	Group I, II A ,II B
Apparatus Standard	IS - 2148 / 81
CMRI Certificate No.	CMRS / TC / H167
Approvals	CCE

CMRI CERTIFIED

CERTIFICATES
CMRI | CCE | BIS

