

REDUCERS

REF Series

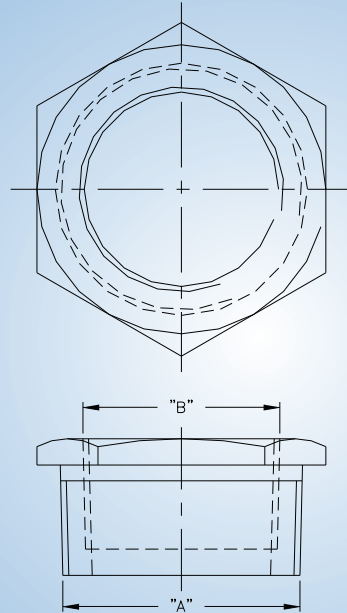

Flanged Reducers
AL/MS -REF (Fxm) Series



Cat. No	Dimension (mm)					Thread Size(Inches)			
	A	B	C	D	E	BSC / ET		NPT / BSP	
						F	G	F	G
REF - 1	25	28				3/4	1/2	-	-
REF - 2	28.5	28				1	1 1/2	-	-
REF - 3	28.5	28				1	3/4	3/4	1/2
REF - 4	37	33				1 1/4	1/2	-	-
REF - 5	37	33				1 1/4	3/4	1	1/2
REF - 6	37	33				1 1/4	1	1	3/4
REF - 7	45	33				1 1/2	1/2	1 1/4	-
REF - 8	45	33				1 1/2	3/4	1 1/4	1/2
REF - 9	45	33				1 1/2	1	1 1/4	3/4
REF - 10	45	33				1 1/2	1 1/4	1 1/4	1

CMRI Certificate No.: CMRI V / REV /1066

CMRI CERTIFIED CERTIFICATES
CMRI | CCE | BIS

www.baliga.com

